

IXIO-DT3

OPENING & SAFETY SENSOR FOR AUTOMATIC SLIDING DOORS

(according to EN 16005 and DIN 18650, including emergency exits)

User's Guide for software version 0501 and higher
(refer to tracking label on product)



Download the BEA DECODER app for a quick overview of settings



DESCRIPTION

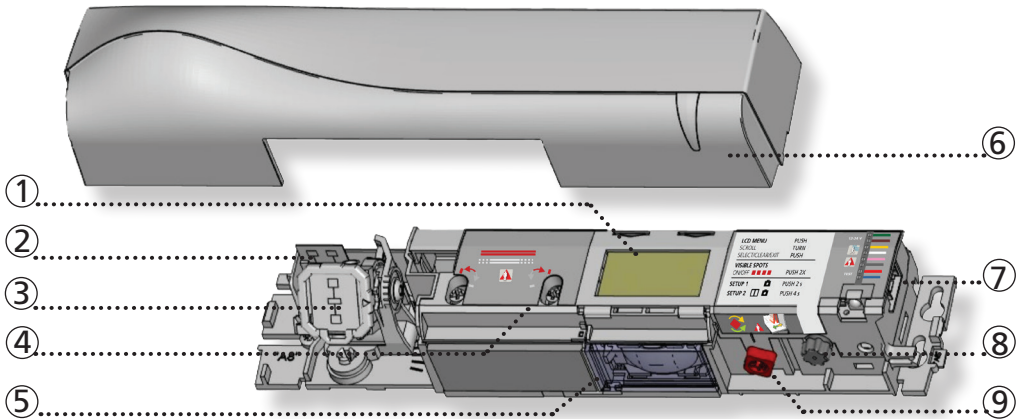

- | | |
|---------------------------------|-------------------------------------|
| 1. LCD | 6. cover |
| 2. radar antenna (narrow field) | 7. main connector |
| 3. radar antenna (wide field) | 8. main adjustment knob |
| 4. IR-curtain width adjustment | 9. IR-curtain angle adjustment knob |
| 5. IR-lenses | |

ACCESSORIES



BA: Bracket accessory



CA: Ceiling accessory

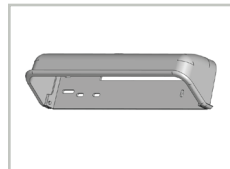

RA: Rain accessory

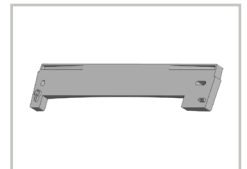

CDA: Curved door accessory



Retrofit interface



Door bell + interface



Smart Daisy Chain hub



9 V battery

HOW TO USE THE LCD?

DISPLAY DURING NORMAL FUNCTIONING

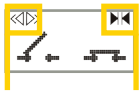

Opening impulse

Safety



Negative display = active output

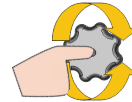

To adjust contrast, push and turn the grey button simultaneously.

During normal function only.

FACTORY VALUE VS. SAVED VALUE



displayed value = factory value



displayed value = saved value

NAVIGATING IN MENUS



Push to enter the LCD-menu



Enter password if necessary

Not during the first minute after power-on of the sensor.



Select your language before entering the first LCD-menu.

During the first 30 seconds after power-on of the sensor or later in the diagnostics menu.



Scroll menu items



Select **Back** to return to previous menu or display.



Select **More** to go to next level:

- basic settings
- advanced settings
- diagnostics

CHANGING A VALUE



Scroll menu up-down



Push to select parameter



current value is displayed



Scroll values up-down

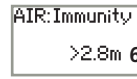

more values are displayed



Push to save new value



new value is displayed

CHANGING A ZIP CODE



See application note on ZIP CODE

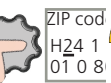
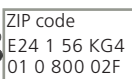

...

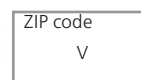
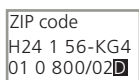

Validate the last digit in order to activate the new ZIP code:

- v = valid ZIP code, values will be changed accordingly
- x = invalid ZIP code, no values will be changed
- v/x = valid ZIP code, but from a different product.

Only available values will be changed.

VALUE CHECK WITH REMOTE CONTROL



Pressing a parameter symbol on your remote control, displays the saved value directly on the LCD-screen.

Do not unlock first.

1 MOUNTING & WIRING

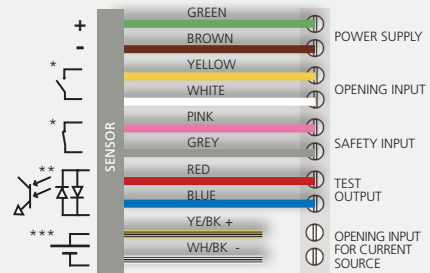
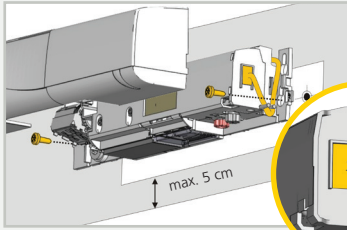

Fixation is compatible with the ACTIV8.

- * Depending on OUTPUT CONFIGURATION settings
- ** For compliance with EN 16005 and DIN 18650, connection to door controller test output is required.
- *** Current source output for emergency exits

2 RADAR OUTPUT CONFIGURATION

RELAY OUTPUT

NOT for emergency exits

NO: normally open

NC: normally closed



OR

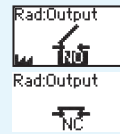

FREQUENCY OUTPUT

for emergency exits

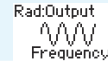

INVERTED FREQUENCY OUTPUT

for specific door operators (NOT for emergency exits)



CURRENT SOURCE OUTPUT

for emergency exits

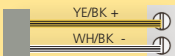

3 RADAR OPENING IMPULSE FIELD

ANGLE

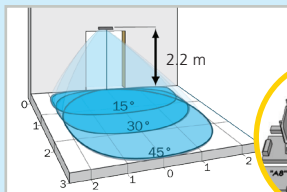

from 15° to 45°, default 30°

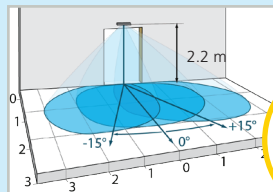
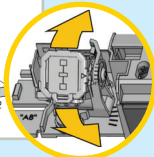

from -15° to 15°, default 0°

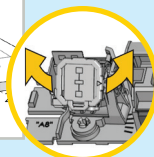

WIDTH

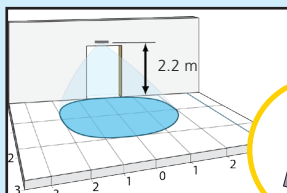

4 m x 2 m (wide)

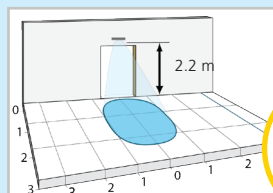
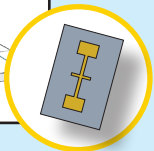

2 m x 2.5 m (narrow)

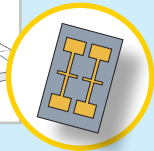

The size of the detection field varies according to the mounting height of the sensor. In emergency exits the full door width must be covered.

4 INFRARED SAFETY FIELD

ANGLE

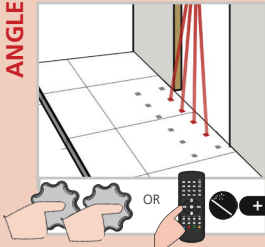

Activate the visible* spots to verify the position of the IR-curtain.

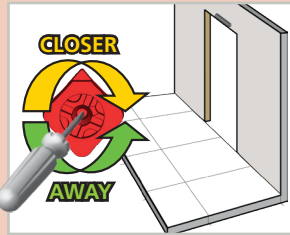

If necessary, adjust the IR-curtain angle (from -7° to 4° , default 0°).

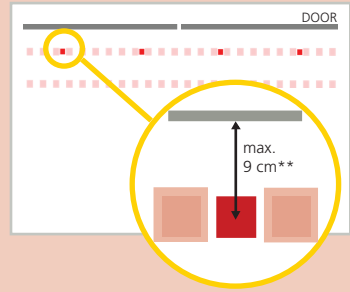

* Visibility depends on external conditions. When spots are not visible, use the Spotfinder to locate the curtains.
 ** The distance between the inner curtain of the inside door sensor and the inner curtain of the outside door sensor should always be smaller than 20 cm. The distance to the door leaf depends therefore on the thickness of the door leaf.

WIDTH

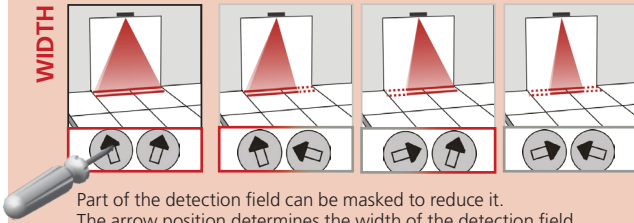

Part of the detection field can be masked to reduce it. The arrow position determines the width of the detection field.

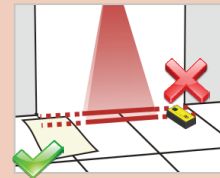

Additional adjustments are possible by LCD or remote control (see p. 5)

Always verify the actual detection field width with a piece of paper and not the Spotfinder, which detects the whole emitted field.

Mounting height	Detection width
2,00 m	2,00 m
2,20 m	2,20 m
2,50 m	2,50 m
3,00 m	d max
3,50 m	d max

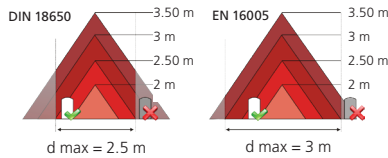

The size of the detection field varies according to the mounting height and the settings of the sensor. The full door width must be covered.

5 SETTINGS

Choose one of the following presettings or adjust the sensor manually (see p.5):

STANDARD: standard in- and outdoor installations

CRITICAL ENVIRONMENT: critical installations due to surroundings or weather

SHOPPING STREET: installations in narrow streets with pedestrian traffic

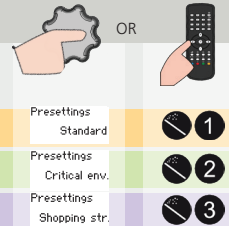

6 SETUP



STEP OUT OF THE INFRARED FIELD!

SETUP 1 (QUICK)

reference picture



SETUP 2 (ASSISTED)

test of full door cycle + reference picture



TEST THE GOOD FUNCTIONING OF THE INSTALLATION BEFORE LEAVING THE PREMISES!

OVERVIEW OF SETTINGS

BASIC



Back
More

PRESETTINGS

RAD: FIELD SIZE

RAD: OUTPUT

IR: IMMUNITY

IR: FREQUENCY

More
Back

ADVANCED



Back
More

RAD: IMMUNITY

RAD: DIRECTION

RAD: HOLD TIME

IR: WIDTH



IR: NUMBER

IR: PRESENCE TIME

IR: OUTPUT

REDIRECTION

SMART DAISY CHAIN*

FACTORY RESET

DOOR BELL*

More
Back

DIAGNOSTICS



ZIP CODE



ID #

ERROR LOG

IR: SPOTVIEW

IR: C1 ENERG

IR: C2 ENERG

	0	1	2	3	4	5	6	7	8	9
PRESETTINGS		standard	critical env.	shopping street			factory values for radar immunity, IR immunity, IR number and redirection increased immunities, 1 curtain			
RAD: FIELD SIZE	small	>	>	>	>	>	>		>	large
RAD: OUTPUT	NO NC	NO NC	NC NO	NC NO	NO NO	current NC	freq NC	NO: normally open NC: normally closed	Inv.freq.*	NC
IR: IMMUNITY		↓ < 2.8 m			↑ > 2.8 m			For conformity to EN 16005 or DIN 18650 at a mounting height of 2.8 m or more, use values 6 and 7.		
IR: FREQUENCY	A	B	Sensors mounted close to each other should have a different frequency.							
ADVANCED		factory value	excludes conformity of the door system according to EN 16005 / DIN 18650. IR immunity on values 4 or 5 is incompatible with IR presence time on value 0 not allowed when the sensor is used in emergency exits							
RAD: IMMUNITY		low		>	>	>	>	>	>	high
RAD: DIRECTION	radar off	bi	uni	uni PRM	uni AWAY	bi Shop	uni Shop	PRM Shop	PRM: for persons with reduced mobility AWAY: unidirectional motion away from sensor shop: automatic adaptation of field size (small shops)	
RAD: HOLD TIME	0.5 s	1 s	2 s	3 s	4 s	5 s	6 s	7 s	8 s	9 s
IR: WIDTH										
IR: NUMBER	service mode	1	2	service mode = no IR detection during 15 minutes (maintenance). This value excludes conformity of the door system to EN 16005 and DIN 18650.						
IR: PRESENCE TIME	motion	15 s	30 s	1 min	2 min	5 min	10 min	20 min	60 min	infinite
IR: OUTPUT		NO NC	NO NO	NC NC	NO NO	current NC	freq NC	NO: normally open NC: normally closed		
REDIRECTION	motion	motion or presence	motion and presence	opening output is active in case of: 0 motion detection 1 motion or presence detection 2 motion and presence detection						
SMART DAISY CHAIN*	off	1/2	2/2	1/3	2/3	3/3	1/2: 1 st sensor in chain of 2; 2/2: 2 nd sensor in chain of 2 1/3: 1 st in chain of 3; 2/3: 2 nd in chain of 3; 3/3: 3 rd in chain of 3			
FACTORY RESET									full reset	partial reset
DOOR BELL*	off	0.05 s	0.10 s	0.25 s	0.50 s	0.75 s	1 s	1.5 s	2 s	5 s

















* Setting in combination with an accessory (see p. 1).
For more information see user's guide of accessory.
** Setting accessible via LCD only

all parameter settings in zipped format (see application note on ZIP CODE)

- unique ID-number
- last 10 errors + day indication
- view of spot(s) that trigger detection
- signal amplitude received on curtain 1
- signal amplitude received on curtain 2

- POWERSUPPLY supply voltage at power connector
- OPERATINGTIME power duration since first startup
- RESET LOG delete all saved errors
- PASSWORD LCD and remote control password (0000= no password)
- LANGUAGE language of LCD-menu
- ADMIN enter code to access admin mode

TROUBLESHOOTING

E1		ORANGE LED flashes 1 x.	The sensor signals an internal fault.	1 Replace sensor.
E2		ORANGE LED flashes 2 x.	The power supply is too low or too high.	1 Check power supply (in the diagnostics menu of the LCD). 2 Check wiring.
E3		ORANGE LED flashes 3 x.	The previous sensor in the daisy chain is faulty	1 Replace previous sensor in the chain
			The SDC setting does not match with the real product position	1 Lock the SDC position setting
E4		ORANGE LED flashes 4 x.	The sensor receives not enough IR-energy.	1 Decrease the angle of the IR-curtains. 2 Increase the IR-immunity filter (values >2.8 m). 3 Deactivate 1 curtain.
E5		ORANGE LED flashes 5 x.	The sensor receives too much IR-energy.	1 Slightly increase the angle of the IR-curtains.
			The sensor is disturbed by external elements.	1 Eliminate the cause of disturbance (lamps, rain cover, door controller housing properly grounded).
E6		ORANGE LED flashes 6 x.	Faulty radar sensor output	1 Replace sensor.
E7		ORANGE LED flashes 7 x.	The internal test of the radar is disturbed.	1 Launch a quick setup:  2 Change radar field angle or antenna. 3 If orange LED flashes again, replace sensor.
E8		ORANGE LED flashes 8 x.	IR power emitter is faulty.	1 Replace sensor.
E9		ORANGE LED flashes 9 x.	Internal reference of the radar is faulty.	1 Replace sensor.
		ORANGE LED is on.	The sensor encounters a memory problem.	1 Cut and restore power supply. 2 If orange LED lights up again, replace sensor.
		RED LED flashes quickly after an assisted setup.	The sensor sees the door during the assisted setup.	1 Move the IR-curtains away from the door. 2 Install the sensor as close to the door as possible. If needed, use a bracket accessory. 3 Launch a new assisted setup.
		RED LED lights up sporadically.	The sensor vibrates.	1 Check if the sensor is fastened firmly. 2 Check position of cable and cover.
			The sensor sees the door.	1 Launch an assisted setup and adjust the IR angle.
			The sensor is disturbed by external conditions.	1 Increase the IR-immunity filter to value 3. 2 Select presetting 2 or 3.
		GREEN LED lights up sporadically.	The sensor is disturbed by rain and/or leaves.	1 Select presetting 2 or 3. 2 Increase radar-immunity filter.
			Ghosting created by door movement.	1 Change radar field angle.
			The sensor vibrates.	1 Check if the sensor and door cover is fastened firmly. 2 Check position of cable and cover.
			The sensor sees the door or other moving objects.	1 Remove the objects if possible. 2 Change radar field size or angle.
		The LED and the LCD-display are off.		1 Check wiring.
		The reaction of the door does not correspond to the LED-signal.		1 Check output configuration setting. 2 Check wiring.
		The LCD or remote control does not react.	The sensor is protected by a password.	1 Enter the right password. If you forgot the code, cut and restore the power supply to access the sensor without entering a password during 1 minute.

LED-SIGNAL



Motion detection



Presence detection



LED flashes



LED flashes x times



LED flashes red-green



LED flashes quickly



LED is off

INSTALLATION



The sensor should be fixed firmly to avoid extreme vibrations.

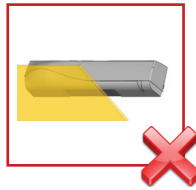

Do not cover the sensor.

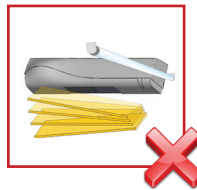

Avoid moving objects and light sources in the detection field.



Avoid highly reflective objects in the infrared field.

MAINTENANCE

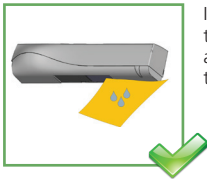

It is recommended to clean the optical parts at least once a year or more if required due to environmental conditions.



Do not use aggressive products to clean the optical parts.

SAFETY

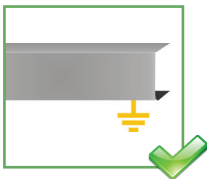

The door control unit and the door cover profile must be correctly earthed.



Only trained and qualified personnel may install and setup the sensor.

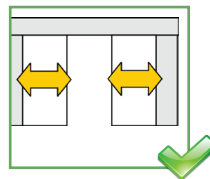

Always test the good functioning of the installation before leaving the premises.

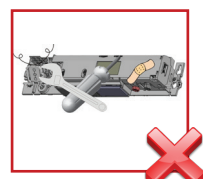

The warranty is invalid if unauthorized repairs are made or attempted by unauthorized personnel.



- The device cannot be used for purposes other than its intended use. All other uses cannot be guaranteed by the manufacturer of the sensor.
- The manufacturer of the door system is responsible for carrying out a risk assessment and installing the sensor and the door system in compliance with applicable national and international regulations and standards on door safety.
- The manufacturer of the sensor cannot be held responsible for incorrect installations or inappropriate adjustments of the sensor.

TECHNICAL SPECIFICATIONS

Supply voltage *:	12 V - 24 V AC +/-10% ; 12 V - 30 V DC +/-10%
Power consumption:	< 2.5 W
Mounting height:	2 m to 3.5 m
Temperature range:	-25°C to +55°C; 0-95% relative humidity, non condensing
Degree of protection:	IP54
Noise:	< 70 dB
Expected lifetime:	20 years

* The Equipment must be powered by a SELV limited power source ensuring double insulation between primary voltages and the Equipment supply. The supply current should be limited to max 3A.



Detection mode:	Motion Min. detection speed: 5 cm/s	Presence Typical response time: < 200 ms (max. 500 ms)
Technology:	Microwave doppler radar Transmitter frequency: 24.150 GHz Transmitter radiated power: < 20 dBm EIRP Transmitter power density: < 5 mW/cm ²	Active infrared with background analysis Spot: 5 cm x 5 cm (typ) Number of spots: max. 24 per curtain Number of curtains: 2
Output:	Solid-state-relay (potential and polarity free) Max. contact current: 100 mA Max. contact voltage: 42 V AC/DC - in switching mode: NO/NC - in frequency mode: pulsed signal in no detection (f = 100 Hz +/- 10%) - in inverted frequency mode: pulsed signal in detection (f = 2.5 Hz) Galvanically isolated current source No detection: current source ON Open circuit voltage: 6.5 V Output voltage available at 10 mA: 3 V min. Typical load: up to 3 optocouplers in series Detection: current source OFF Open-circuit remained voltage: < 500 mV	Solid-state-relay (potential and polarity free) Max. contact current: 100 mA Max. contact voltage: 42 V AC/DC Holdtime: 0.3 to 1 s
Test input:		Sensitivity: Low: < 1 V; High: > 10 V (max. 30 V) Response time on test request: typical: < 5 ms
Safety Standards:	EN ISO 13849-1 PL «d» CAT. 2 EN 16005 (emergency exits) DIN 18650-1 (emergency exits) AutSchR (only applicable for radar output in frequency mode and current source output)	EN ISO 13849-1 PL «C» CAT. 2 (under the condition that the door control system monitors the sensor at least once per door cycle) EN 16005 (protective devices) DIN 18650-1 (protective devices) EN 12978

Specifications are subject to changes without prior notice.
All values measured in specific conditions and with a temperature of 25°C.



BEA SA | LIEGE Science Park | Allée des Noisetiers, 5 - 4031 ANGLEUR [BELGIUM] | T +32 4 361 65 65 | F +32 4 361 28 58 | info-eu@beasensors.com | www.beasensors.com



BEA hereby declares that the IXIO-DT3 is in conformity with the European directives 2014/53/EU (RED), 2006/42/EC (Machinery) and 2011/65/EU (ROHS).
Notified Body for EC-type inspection: 0044 - TÜV NORD CERT GmbH, Langemarckstr. 20, D-45141 Essen
EC-type examination certificate number: 44 205 13089612
Angleur, february 2021 Estelle GRAAS



The complete declaration of conformity is available on our website
This product should be disposed of separately from unsorted municipal waste

